



# Makita Werkzeug Ges.m.b.H.

Airportstr. 4, 2401 Fischamend

Tel: 02232 / 777 00

Fax: 02232 / 777 00 - 40

Mail: verkauf@makita.at

Web: www.makita.at

## Makita Service Information / Model: HM1810

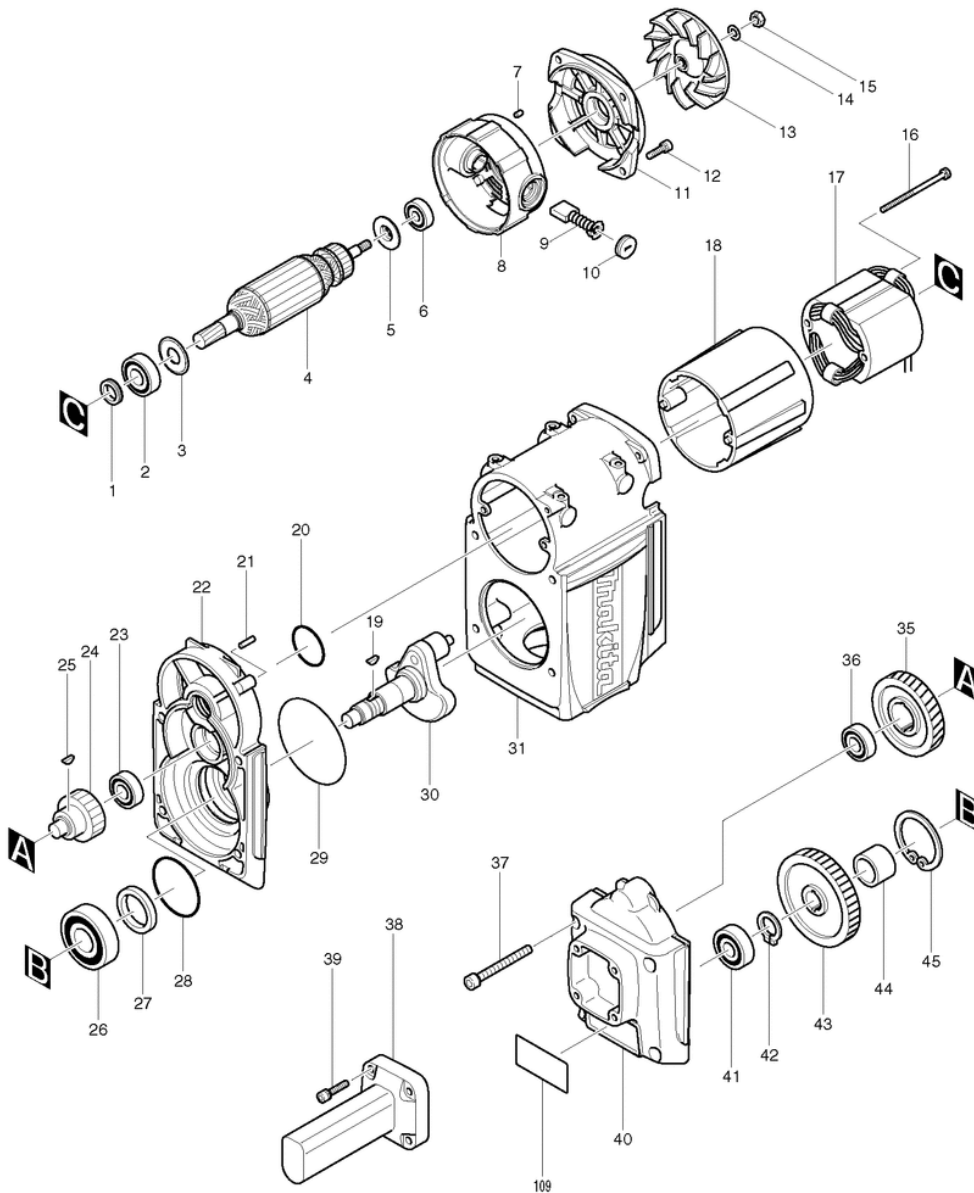



**Makita Service Information / Model: HM1810**

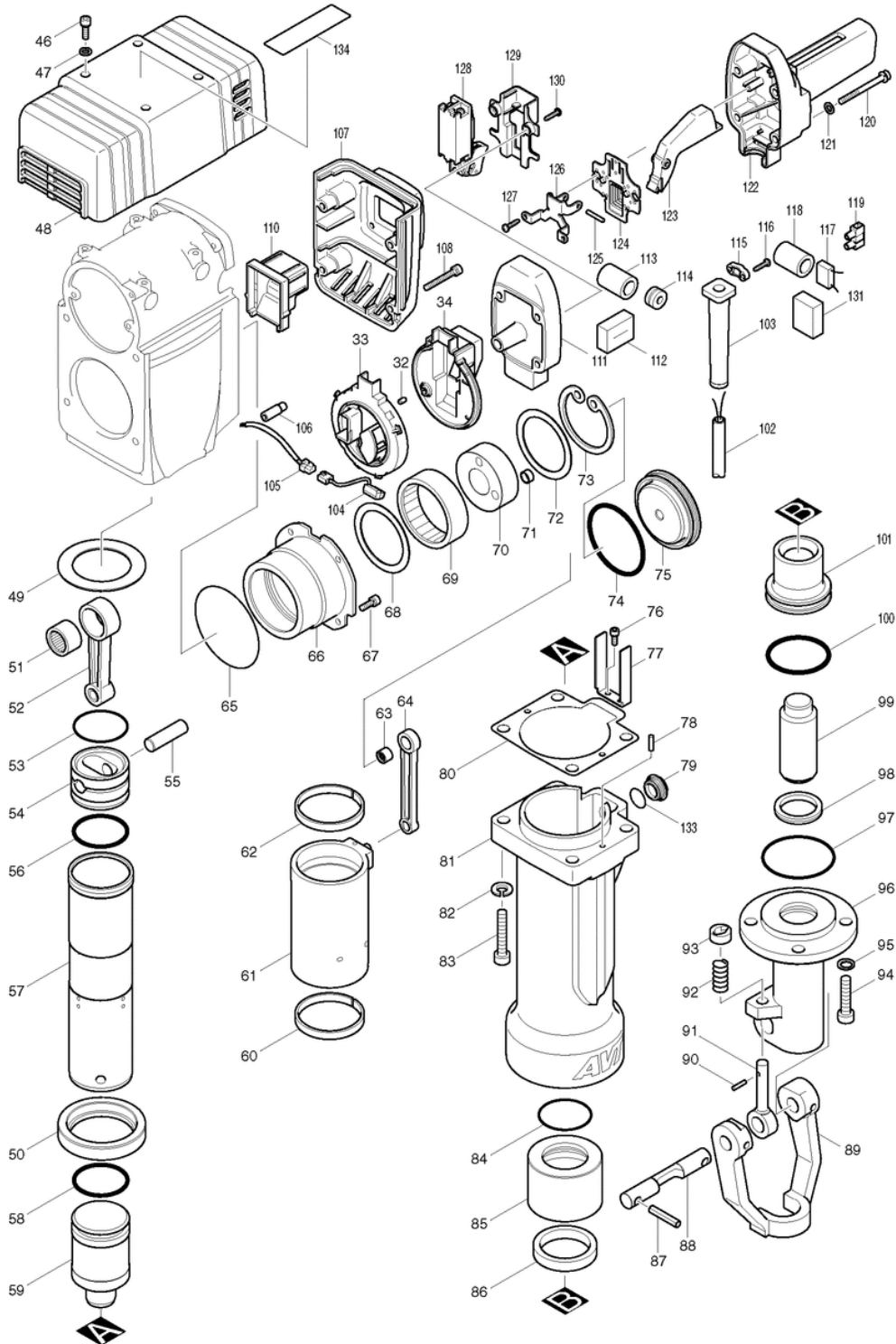



# Makita Werkzeug Ges.m.b.H.

Airportstr. 4, 2401 Fischamend

Tel: 02232 / 777 00

Fax: 02232 / 777 00 - 40

Mail: verkauf@makita.at

Web: www.makita.at

## Makita Service Information / Model: HM1810

POS	Bestell-Nr.	Artikelbeschreibung	Stk.	Stk.Preis
1	322566-3	DICHTUNG HM1800/1801/1810	1	N/A
2	211256-2	*KUGELLAGER 6203LLB 211256-2	1	N/A
3	267706-5	STAUBDICHTUNG HM1800/1801/1810	1	N/A
4	516922-9	ANKER HM1801/HM1810	1	N/A
4		*** INC. 1-3,5,6		N/A
5	681646-7	ISOLIERSCHEIBE HM1800/1801/18	1	N/A
6	211066-7	KUGELLAGER 6200LLB	1	N/A
6.2	211087-9	KUGELLAGER	1	N/A
7	263002-9	GUMMISTIFT	4	N/A
8	154586-7	MOTORGEHÄUSE B HM1801/1810	1	N/A
9	191957-7	KOHLLEN CB-204	1	N/A
10	643710-2	KAPPE	2	N/A
11	317899-9	LAGERSCHILD HM1801/1810	1	N/A
12	265366-7	INBUSSCHRAUBE M6x22	4	N/A
13	240024-6	LÜFTERFLÜGEL HM1800/1801/1810	1	N/A
14	253165-9	U-SCHEIBE 8	1	N/A
15	931402-8	MUTTER M8 BHR241	1	N/A
16	265344-7	*FELDSCHRAUBE M5x85	2	N/A
17	628943-0	FELD HM1801/HM1810	1	N/A
18	414787-2	MOTORGEH. A HM1800/1801/1810	1	N/A
19	254001-2	KEIL 4	2	N/A
20	213507-9	O-RING 40 HR1800/HR2220/2210	1	N/A
21	256151-9	STIFT 5 HM1800/1801/1810	1	N/A
22	154585-9	GETRIEBEGEHÄUSE HM1801/1810	1	N/A
22		*** INC. 20,28		N/A
23	211209-1	KUGELLAGER 6202	1	N/A
24	226251-9	ZAHNRAD 22 HM1800/1801/1810	1	N/A
25	254001-2	KEIL 4	2	N/A
26	211361-5	KUGELLAGER 6305LLB	1	N/A
27	213476-4	ÖLDICHTUNG HM1800/1801/1810	1	N/A
28	213721-7	O RING 61 HM1800/1801	1	N/A
29	213806-9	O-RING 90 HR2510/HM1202C/1801/	1	N/A
30	154588-3	KURBELWELLE HM1810	1	N/A
31	317903-4	*GETRIEBEGEHÄUSE HM1801/1810	1	N/A
31.2	318027-9	GETRIEBEGEHÄUSE HM1801/1810	1	N/A
32	263002-9	GUMMISTIFT	1	N/A
33	418955-9	*KURBELGEHÄUSEDECK. HM1801/181	1	N/A
33.2	419262-3	KURBELGEHÄUSED. neu HM1801/10	1	N/A
34	418953-3	*ISOLLIERABDECKUNG HM1801/181	1	N/A
34.2	419263-1	*ISOLLIERABD. HM1801/1810 ne	1	N/A



## Makita Werkzeug Ges.m.b.H.

Airportstr. 4, 2401 Fischamend

Tel: 02232 / 777 00

Fax: 02232 / 777 00 - 40

Mail: verkauf@makita.at

Web: www.makita.at

### Makita Service Information / Model: HM1810

POS	Bestell-Nr.	Artikelbeschreibung	Stk.	Stk.Preis
35	221793-8	ZAHNRAD 50 HM1800/1801/1810	1	N/A
36	211209-1	KUGELLAGER 6202	1	N/A
37	922496-4	INBUSSCHRAUBE M8x75	4	N/A
38	418415-1	GRIFF HM1800/1801/1810	1	N/A
39	922353-6	*SCHRAUBE	4	N/A
40	317902-6	GETRIEBEGEHÄUSED. HM1801/1810	1	N/A
41	211214-8	KUGELLAGER 6302	1	N/A
42	961060-6	SEEGERING S-20 HM3541FC	1	N/A
43	226242-0	*ZAHNRAD 47 HM1800/1801/1810	1	N/A
44	331416-1	HÜLSE 25 HM1800/1801/1810	1	N/A
45	962301-3	SEEGERING R-62	1	N/A
46	922331-6	*SCHRAUBE	4	N/A
47	941152-7	BEILAGSCHEIBE 6	4	N/A
48	183984-8	*MOTORGEHÄUSEABDE. HM1801/181	1	N/A
48		*** INC. 134		N/A
48.2	419324-7	MOTORGEHÄUSED. HM1801/1810 neu	1	N/A
49	267296-8	DISTANZSCHEIBE 63 HM1801/1810	1	N/A
50	324580-5	Distanzring HM1801/1810	1	N/A
51	212358-7	NADELLAGER 2520 HM1800/1801/	1	N/A
52	322476-4	PLEUEL HM1800/1801/1810	1	N/A
53	213662-7	O-RING 55 AN7000/HM1801/1810	1	N/A
54	324536-8	KOLBEN HM1801/1810	1	N/A
55	268130-5	STIFT 15 HM1801/1810	1	N/A
56	213666-9	O-RING 52 HM1800/1801/1810	1	N/A
57	331694-3	ZYLINDER 62 HM1801/1810	1	N/A
58	213666-9	O-RING 52 HM1800/1801/1810	1	N/A
59	324546-5	SCHLÄGER HM1801/1810	1	N/A
60	418949-4	DISTANZRING 68 HM1810	1	N/A
61	154589-1	Ausgleichhülse HM1810	1	N/A
62	418949-4	DISTANZRING 68 HM1810	1	N/A
63	212075-9	*ROLLENNADELLAGER HM1810/HR40	1	N/A
64	324535-0	*PLEUEL HM1810	1	N/A
64.2	154946-3	PLEUEL HM1810 NEU	1	N/A
65	213855-6	O-RING 95 HM1400/1801/TW1000	1	N/A
66	317900-0	*Getriebebox HM1810	1	N/A
66.2	318028-7	Getriebebox HM1810 NEU für Rep	1	N/A
67	922331-6	*SCHRAUBE	4	N/A
68	267297-6	Scheibe 65 HM1810	1	N/A
69	212701-0	NADELLAGER 7025 HM1810	1	N/A
70	154587-5	Exzenter HM1810	1	N/A



# Makita Werkzeug Ges.m.b.H.

Airportstr. 4, 2401 Fischamend

Tel: 02232 / 777 00

Fax: 02232 / 777 00 - 40

Mail: verkauf@makita.at

Web: www.makita.at

## Makita Service Information / Model: HM1810

POS	Bestell-Nr.	Artikelbeschreibung	Stk.	Stk.Preis
71	257267-3	*Ring 10 HM1810	1	N/A
71.2	331718-5	Distanzring HM1810 für Rep.	1	N/A
72	267297-6	Scheibe 65 HM1810	1	N/A
73	962354-2	SEEGERING R-80 HM1810	1	N/A
74	213765-7	O-RING 70 HM1810	1	N/A
75	418952-5	HALTER HM1810	1	N/A
76	265908-7	*INBUSSCHRAUBE 5x16 JR3010/H	2	N/A
76.2	266464-0	INBUSSCHRAUBE 5x20 JR3010/HM	2	N/A
77	345569-0	Platte HM1810	1	N/A
78	256151-9	STIFT 5 HM1800/1801/1810	1	N/A
79	324606-3	*Kappe HM1801/1810	1	N/A
79.2	450347-6	Kappe HM1801/1810 neu	1	N/A
80	162241-7	Dichtung HM1801/1810	1	N/A
81	317905-0	*ZYLINDERGEHÄUSE HM1810	1	N/A
81.2	318354-4	ZYLINDERGEHÄUSE HM1810	1	N/A
82	942301-9	SPRENGRING 12	4	N/A
83	922677-0	*INBUSSCHRAUBE M12x55	4	N/A
84	213660-1	O-RING 53 HM1800/1801/1500/1	1	N/A
85	322548-5	ZYLINDER B HM1800/1801/1810	1	N/A
86	262050-5	GUMMIRING 54 HM1500/1801/1810	1	N/A
87	951272-9	KERBSTIFT 8-40	2	N/A
88	324238-6	Verriegelungsstift HM1800/1801	1	N/A
89	324236-0	BÜGEL HM1800/1801/1810	1	N/A
90	256219-1	STIFT 4 HM1500/1801/HR3000/3	2	N/A
91	322477-2	BÜGELHALTER HM1800/1801/1500B	2	N/A
92	233083-7	DRUCKFEDER 12 HM1800/1801/1500	2	N/A
93	322560-5	HALTERRING HM1500/1304B/1801/	2	N/A
94	265989-1	INBUSSCHRAUBE M12x45	4	N/A
95	253989-3	SPRENGRING 12 HM1500/1801/18	4	N/A
96	324539-2	WERKZEUGHALTER HM1801/1810	1	N/A
97	213755-0	O-RING 75 HM1400/BO5010/4900	1	N/A
98	213517-6	X-RING 40 HM1400/1801/1810	1	N/A
99	324545-7	SCHLAGBOLZEN HM1801/1810	1	N/A
100	213667-7	O-RING 60 HM1800/1801/1810/A	1	N/A
101	324541-5	SCHLAGBOLZENHALTER HM1801/1810	1	N/A
102	695123-3	*KABEL 1.5-2-4.0 KP312S	1	N/A
103	682546-4	KABELSCHUTZ 12-125	1	N/A
104	631671-8	Kontrolllampe HM1801/1810	1	N/A
105	638378-7	ANSCHLUSSDRAHT HM1801/1810	1	N/A
106	418951-7	LINSE HM1801/1810	1	N/A



## Makita Werkzeug Ges.m.b.H.

Airportstr. 4, 2401 Fischamend

Tel: 02232 / 777 00

Fax: 02232 / 777 00 - 40

Mail: verkauf@makita.at

Web: www.makita.at

### Makita Service Information / Model: HM1810

POS	Bestell-Nr.	Artikelbeschreibung	Stk.	Stk.Preis
107	317901-8	*GEHÄUSEDECKEL HM1801/1810	1	N/A
108	922366-7	*INBUSSCHRAUBE M6x45	4	N/A
109	861399-6	*TYPENSCHILD HM1810	1	N/A
110	418954-1	*Deckel - oben HM1801/1810	1	N/A
111	419044-3	GRIFFHALTEPLATTE HM1800/1801/	1	N/A
112	685700-9	SCHAUMGUMMI	1	N/A
113	685722-9	SCHAUMGUMMI 4302C/3620/RP.usw	1	N/A
114	688131-1	ENTSTÖRFILTER	1	N/A
115	687053-2	*ZUGENTLASTUNG 2012NB, BFR440	1	N/A
116	265995-6	*GEWINDESCHNEIDSCHRAUBE	2	N/A
117	645200-1	*ENTSTÖRKONDENSATOR	1	N/A
118	685722-9	SCHAUMGUMMI 4302C/3620/RP.usw	1	N/A
119	654554-5	*Kontaktklemme HM1801/1810	2	N/A
120	265535-0	INBUSSCHRAUBE M6x65 HM1801/10	4	N/A
121	941152-7	BEILAGSCHEIBE 6	4	N/A
122	418333-3	HANDGRIFFSCHALE HM1800/1801/1	1	N/A
123	418332-5	SCHALTERHEBEL HM1800/1801/1810	1	N/A
124	421850-4	STAUBSCHUTZ HM1800/1801/1810	1	N/A
125	256206-0	STIFT 4 T1022DW/HM1800/1801/	1	N/A
126	345355-9	HALTEPLATTE HM1800/1801/1810	1	N/A
127	265995-6	*GEWINDESCHNEIDSCHRAUBE	2	N/A
128	651131-4	SCHALTER SR2600/HM1801/1810	1	N/A
129	419045-1	SCHALTERDECKEL HM1801/1810	1	N/A
130	265995-6	*GEWINDESCHNEIDSCHRAUBE	2	N/A
131	685718-0	*SCHAUMGUMMI 9035N/JR3000VT/H	1	N/A
133	213373-4	O-RING 22	1	N/A
133.2	213953-6	O-RING 24 HM1801/10 neu	1	N/A
134	819213-0	*MAKITA-Logo Aufkleber	1	N/A
135	265995-6	*GEWINDESCHNEIDSCHRAUBE	1	N/A
136	424132-3	GUMMIKAPPE HM1810-01	2	N/A
137	819352-6	CLEAR LABEL	1	N/A
1001	783203-8	INBUSSCHLÜSSEL 5	1	N/A