



# Makita Werkzeug Ges.m.b.H.

Airportstr. 4, 2401 Fischamend

Tel: 02232 / 777 00

Fax: 02232 / 777 00 - 40

Mail: verkauf@makita.at

Web: www.makita.at

## Makita Service Information / Model: HM111C

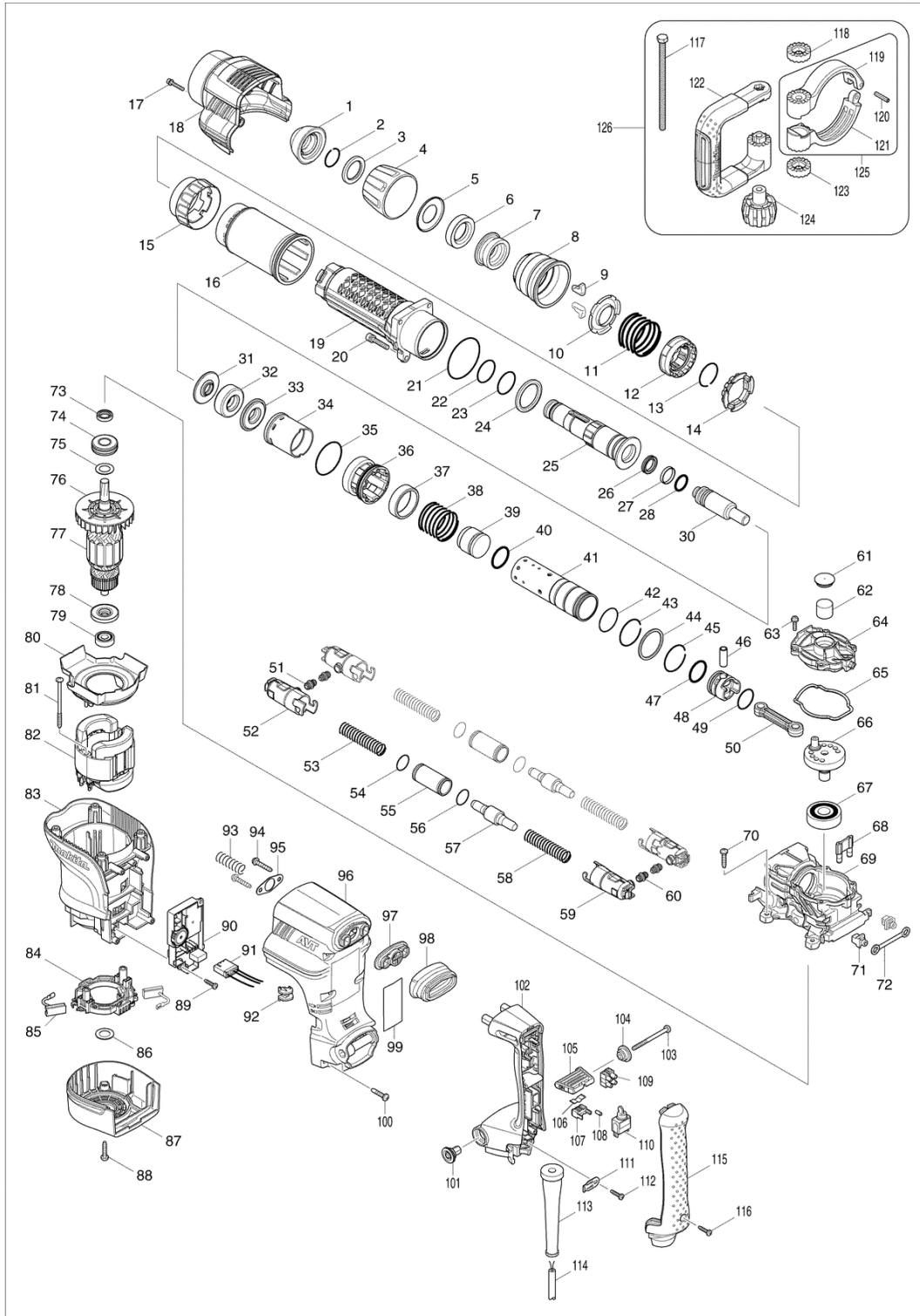



## Makita Werkzeug Ges.m.b.H.

Airportstr. 4, 2401 Fischamend

Tel: 02232 / 777 00

Fax: 02232 / 777 00 - 40

Mail: [verkauf@makita.at](mailto:verkauf@makita.at)

Web: [www.makita.at](http://www.makita.at)

### Makita Service Information / Model: HM1111C

POS	Bestell-Nr.	Artikelbeschreibung	Stk.	Stk.Preis
1	286285-4	Kappe HR4001C-HR5211C neu	1	N/A
2	233948-3	RINGFEDER 25 HR5211C/5210C	1	N/A
3	257308-5	RING HM1101C/HM1111C	1	N/A
4	450064-8	BOHRFUTTERDECKEL HR4501C	1	N/A
5	346247-5	ABDECKKAPPE 28 HM1101C/1111C	1	N/A
6	262161-6	GUMMIRING 28 HM1101C/HM1111C	1	N/A
7	324752-2	BOHRFUTTERRING HR5211C/5210C	1	N/A
8	451836-4	AUSLÖSEDECKEL HM1101C/HM1111C	1	N/A
9	310178-4	HALTEBÜGEL HR5211C/5210C/5201	2	N/A
10	345804-6	FEDERFÜHRUNG HR5211C/5210C	1	N/A
11	234180-2	DRUCKFEDER 47 HM1101C/HM1111C	1	N/A
12	313193-7	STELLRING HM1101C/HM1111c	1	N/A
13	233982-3	FEDERRING 33 HM1101C/HM1111C	1	N/A
14	325904-8	FIXIERRING HM1101C/HM1111C	1	N/A
15	451842-9	STELLRINGDECKEL HM1101C/1111C	1	N/A
16	451835-6	ABDECKUNG HM1101C/HM1111C	1	N/A
17	922148-7	INBUSSCHRAUBE M4x25 HR2511C	1	N/A
18	451845-3	GETRIEBEGEHÄUSEDECKEL HM1111C	1	N/A
19	140411-8	VORDERGEHÄUSE HM1101C/HM1111C	1	N/A
20	922353-6	*SCHRAUBE	4	N/A
21	213654-6	O-RING 60 HR3850/HM0810/AN923	1	N/A
22	213492-6	O-RING 32 HR5211C/5210C/5201C	1	N/A
23	213492-6	O-RING 32 HR5211C/5210C/5201C	1	N/A
24	262135-7	RING 36 HR4501C	1	N/A
25	325901-4	WERKZEUGHALTER HM1101C/HM1111C	1	N/A
26	213281-9	X-RING 18 HR4011C-Serie	1	N/A
27	213392-0	FLUORIDRING 25 HR4000/4500/4	1	N/A
28	213317-4	O-RING 20 HR4000/4500/4011C/	1	N/A
30	325902-2	SCHLAGBOLZEN HM1101C/HM1111C	1	N/A
31	325903-0	LAGER 19 HM1101C/HM1111C	1	N/A
32	422053-3	GUMMIRING 20 HM1101C/HM1111C	1	N/A
33	325903-0	LAGER 19 HM1101C/HM1111C	1	N/A
34	412096-3	GLEITHÜLSE HM1101C/HM1111C	1	N/A
35	213606-7	O-RING 48	1	N/A
36	318604-7	ZYLINDERFÜHRUNG HM1101C/1111C	1	N/A
37	313194-5	RING 39 HM1101C/HM1111C	1	N/A
38	234178-9	DRUCKFEDER 40 HM1101C/HM1111C	1	N/A
39	325905-6	SCHLÄGER HM1101C/HM1111C	1	N/A
40	213536-2	O-RING 27 HM1101C	1	N/A
41	331892-9	ZYLINDER 35 HM1101C/HM1111C	1	N/A



# Makita Werkzeug Ges.m.b.H.

Airportstr. 4, 2401 Fischamend

Tel: 02232 / 777 00

Fax: 02232 / 777 00 - 40

Mail: verkauf@makita.at

Web: www.makita.at

## Makita Service Information / Model: HM1111C

POS	Bestell-Nr.	Artikelbeschreibung	Stk.	Stk.Preis
42	213458-6	O-RING 34 HP2000/HP2010/N/DA3	1	N/A
43	233981-5	FEDERRING 38 HM1101C/HM1111C	1	N/A
44	267423-7	SCHEIBE 40 HM1101C/HM1111C	1	N/A
45	233981-5	FEDERRING 38 HM1101C/HM1111C	1	N/A
46	331911-1	ROHR 10 HM1101C/HM1111C	1	N/A
47	213536-2	O-RING 27 HM1101C	1	N/A
48	451833-0	KOLBEN HM1101C/HM1111C	1	N/A
49	213415-4	O-RING 28 HM1100C/9403/HM1140	1	N/A
50	451834-8	PLEUEL HM1101C/HM1111C	1	N/A
51	422054-1	GUMMIROHR HM111CU	2	N/A
52	451843-7	ROHRHALTER (VORNE) HM1111C	2	N/A
53	234179-7	DRUCKFEDER 14 HM1111C	2	N/A
54	213961-7	O-RING	2	N/A
55	331893-7	ROHR 20 HM1111C	2	N/A
56	213961-7	O-RING	2	N/A
57	325906-4	GEGENGEWICHT HM1111C	2	N/A
58	234179-7	DRUCKFEDER 14 HM1111C	2	N/A
59	451844-5	ROHRHALTER (HINTEN) HM1111C	2	N/A
60	422054-1	GUMMIROHR HM111CU	2	N/A
61	424311-3	FILTER KAPPE HM1101C/HM1111C	1	N/A
62	443127-7	FILTER HR3530/HM1203C	1	N/A
63	911133-5	*SCHRAUBE M4x18 Hm1203C	5	N/A
64	451838-0	GETRIEBEKAPPE HM1101C/HM1111C	1	N/A
65	424312-1	DICHTUNGSRING HM1101C/HM1111C	1	N/A
66	325899-5	KURBELWELLE HM1101C/HM1111C	1	N/A
67	211279-0	KUGELLAGER 6303LLU HM0810/HM0	1	N/A
68	451848-7	ROHR HM1111C	1	N/A
69	140407-9	GETRIEBEGEHÄUSE HM1111C	1	N/A
70	266041-8	SCHNEIDSCHRAUBE	4	N/A
71	419008-7	FÜHRUNG HR4011C-Serie/HM1203C	2	N/A
72	423345-3	PLATTE HR4011C-Serie	1	N/A
73	213133-4	*SIMMERRING 12 HR2800/3540C	1	N/A
74	211295-2	KUGELLAGER HM1101C/HM1111C	1	N/A
75	267215-4	SCHEIBE 15 BTW/BTD200SH/GA70	1	N/A
76	241908-1	LÜFTERRAD 80 9047F/SF/HM1202C	1	N/A
77	517858-5	ANKER HM1101C	1	N/A
77		*** INC. 74-76,78,79		N/A
78	681642-5	ISOLIERSCHEIBE HM1213C	1	N/A
79	210059-1	*KUGELLAGER 6000DDW/HM1203C	1	N/A
80	451837-2	LUFTABLEITPLATTE HM1101C/1111C	1	N/A



# Makita Werkzeug Ges.m.b.H.

Airportstr. 4, 2401 Fischamend

Tel: 02232 / 777 00

Fax: 02232 / 777 00 - 40

Mail: verkauf@makita.at

Web: www.makita.at

## Makita Service Information / Model: HM111C

POS	Bestell-Nr.	Artikelbeschreibung	Stk.	Stk.Preis
81	266568-8	SELBSTSCHNEID.SCHRAUBE 5x80	2	N/A
82	623418-4	FELD HM1101C	1	N/A
83	451840-3	MOTORGEHÄUSE HM1101C/HM1111C	1	N/A
84	638700-8	KOHLLENHALTEREINHEIT	1	N/A
85	194412-8	*KOHLEN CB-171 HR5211C/5210C	1	N/A
85.2	195844-2	*KOHLEN CB-175 HR5211C/5210C	1	N/A
86	267215-4	SCHEIBE 15 BTW/BTD200SH/GA70	1	N/A
87	451839-8	MOTORGEHÄUSEDECKEL	1	N/A
88	266041-8	SCHNEIDSCHRAUBE	2	N/A
89	265995-6	*GEWINDESCHNEIDSCHRAUBE	2	N/A
89.2	266300-0	*SELBSTSCHNEID. SCHRAUBE 4x18	2	N/A
90	631968-5	REGELELEKTRONIK HM1111C	1	N/A
91	638718-9	ANSCHLUSSDRAHT HM1101C/HM1111C	1	N/A
92	450240-4	LINSE HR3200C-Serie	1	N/A
93	233434-4	DRUCKFEDER 11 HR4011C/5211C	1	N/A
94	266173-1	KUNSTSTOFFSCHRAUBE	2	N/A
95	346246-7	PLATTE HM1111C	1	N/A
96	451846-1	GRIFFPLATTE HM1111C	1	N/A
97	419783-5	HALTERUNG HR5211C	1	N/A
98	424001-8	STAUBDECKEL HR5211C	1	N/A
99	868068-0	HM1111C NAME PLATE	1	N/A
100	266041-8	SCHNEIDSCHRAUBE	6	N/A
101	451431-0	MITNEHMER HM0871C	1	N/A
102	140409-5	HANDGRIFF HM1111C	1	N/A
103	266029-8	*SELBSTSCHNEID. SCHRAUBE 5x65	1	N/A
104	450352-3	Ansatzhülse HR3210C/10FCT	1	N/A
105	450896-3	Gleithebel HM1213C	1	N/A
106	232209-8	BLATTFEDER HM0860/HR4010/001C	1	N/A
107	450891-3	GRIFFHALTER HM1213C	1	N/A
108	263027-3	GUMMISTIFT 4 HM0860C/HR4010C	1	N/A
109	654531-7	Kontaktklemme HT-345	1	N/A
110	651418-4	SCHALTER ST115A-40	1	N/A
111	687169-3	KABELKLEMMPLATTE HP1620/1621/	1	N/A
112	265995-6	*GEWINDESCHNEIDSCHRAUBE	1	N/A
113	682560-0	KNICKSCHUTZ	1	N/A
114	695123-3	*KABEL 1.5-2-4.0 KP312S	1	N/A
115	451841-1	GRIFFSCHALE HM1101C/HM1111C	1	N/A
116	265995-6	*GEWINDESCHNEIDSCHRAUBE	1	N/A
117	265439-6	6-KANTSCHRAUBE M8x15 HM1213C	1	N/A
118	417002-3	Halterung f. SCHELLE. HM1213	1	N/A



## Makita Werkzeug Ges.m.b.H.

Airportstr. 4, 2401 Fischamend

Tel: 02232 / 777 00

Fax: 02232 / 777 00 - 40

Mail: verkauf@makita.at

Web: www.makita.at

### Makita Service Information / Model: HM1111C

POS	Bestell-Nr.	Artikelbeschreibung	Stk.	Stk.Preis
119	317282-0	SIDE HANDLE BASE 68A	1	N/A
120	951166-8	KERBSTIFT 5-24 HM1213C	1	N/A
121	317283-8	SIDE HANDLE BASE 68B	1	N/A
122	417003-1	SEITLICHER GRIFF HM1213C	1	N/A
123	417002-3	Halterung f. SCHELLE. HM1213	1	N/A
124	252640-2	FLÜGELMUTTER M8 HM1213C	1	N/A
125	151769-0	GRIFFHALTER 68 (ALU) HR4000C	1	N/A
125		*** INC. 119-121		N/A
126	134890-0	SEITL.GRIFF-D HR4000/4011C-Ser	1	N/A
126		*** INC. 117-124		N/A
1001	A-80787	*Spitzmeis. 280 SDS-MAX HM1213	1	N/A
1002	194683-7	*FETT F. BOHRER & MEISELSCHAFT	1	N/A
1003	443122-7	GEWEBE-TUCH HR4011C-Serie	1	N/A
1004	140561-9	PLASTIC CASE COMPLETE	1	N/A
1005	819925-5	HM1111C PLASTIC CASE LABEL	2	N/A